

Montaje Protector Carenaje Superior



Nota:

No apriete todos los tornillos hasta que no estén completamente alineadas todas las perforaciones con respecto a los puntos de sujeción.

Antes de realizar la instalación, verifique todo el manual e identifique que las partes y las piezas estén completas.

Herramientas:

Kit llaves hexágonas Kit llaves Torx
Kit llaves Boca Fija



Kit Instalado



Instalación

Instale platina de sujeción central (2) en el soporte de farola central de la moto ubicada detrás de la luz principal de la moto.

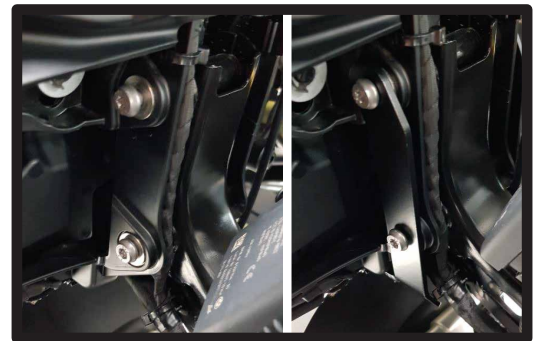

Utilice los mismos tornillos originales de la moto para instalar la platina.

El Kit Contiene

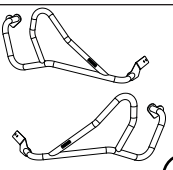
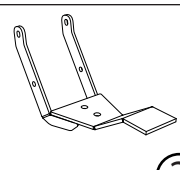
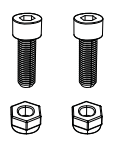
<p>Protector Carenaje Derecho/Izquierdo</p>  <p>①</p> <p>Cantidad: 1 c/u</p>	<p>Platina sujeción Central</p>  <p>②</p> <p>Cantidad: 1</p>	<p>Socket M8x20 Tuerca Seg M8</p>  <p>③</p> <p>Cantidad: 4</p>
---	---	---

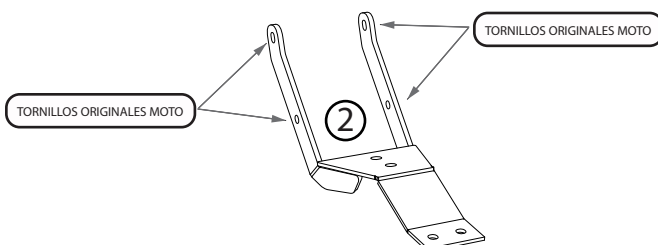

En los puntos de sujeción mostrados se instala las barras de carenaje las cuales



Al terminar la instalación de las partes, verifique que estén alineadas y que toda la tornillería esté debidamente apretada; reajuste todos los tornillos.

Montaje Protector Carenaje Superior

Nota:

No apriete todos los tornillos hasta que no estén completamente alineadas todas las perforaciones con respecto a los puntos de sujeción.

Antes de realizar la instalación, verifique todo el manual e identifique que las partes y las piezas estén completas.

Herramientas:

Kit llaves hexágonas

Kit llaves Boca Fija



las Barras derecha e Izquierda (1) tiene sentido de instalación con respecto a la platina central antes instalada, verificar imagen con instalación

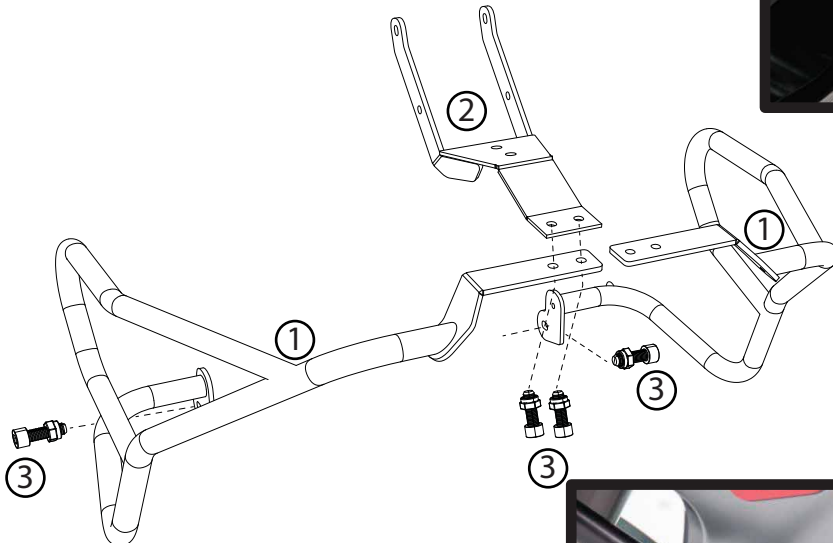
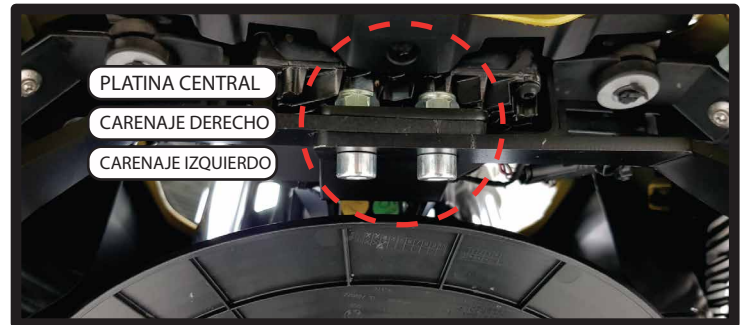

las Barras Superiores se instala en los puntos de las platinas que se señala en la imagen, esto mismo se encuentra para el lado Izquierdo como para el Derecho

IMPORTANTE:

Los protectores de Carenaje Superior DEPENDEN de los protectores inferiores previamente instalados de la marca Mastech.

Este Producto no es compatible con accesorios de otras Marcas



Al terminar la instalación de las partes, verifique que estén alineadas y que toda la tornillería esté debidamente apretada; reajuste todos los tornillos.



MASTECH

BMW 750/850 GS

Assembly Instructions Upper Crash Bars

Esp/Spa Ing/Eng

Note :

Do not tighten the screws until they are completely aligned with the holes.
Before the installation, please verify through the manual that all pieces and parts are complete.

Tools Required:

Hex Allen Wrench Set Torx Wrench Set
Combination Wrench Set



Assembled Kit



Installation

Install the Center Mounting Sheet (2) in the support of the central light of the motorcycle. This is behind the central light of the motorcycle



instalation Kit

Crash Bar Righth/Left		Center Mounting sheet		Socket M8x20 Nut M8	
①		②		③	
Qty:	1RH/LH	Qty:	1	Qty:	4

Use the original motorcycle screws to install the Center Mounting Sheet

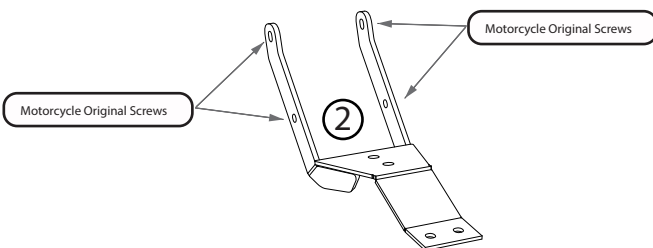

install both crash bar in the hole that it as show in the picture



After the installation of the parts, please check that they are aligned and that all the hardware is properly tightened

Assembly Instructions Upper Crash Bars

Note :

Do not tighten the screws until they are completely aligned with the holes.
Before the installation, please verify through the manual that all pieces and parts are complete.

Tools Required:

Hex Allen Wrench Set Torx Wrench Set
Combination Wrench Set



The Right and Left Bars (1) have a sequence of installation. first Install the Right Crash Bar, continue with de Left Crash bar as show in the picture.

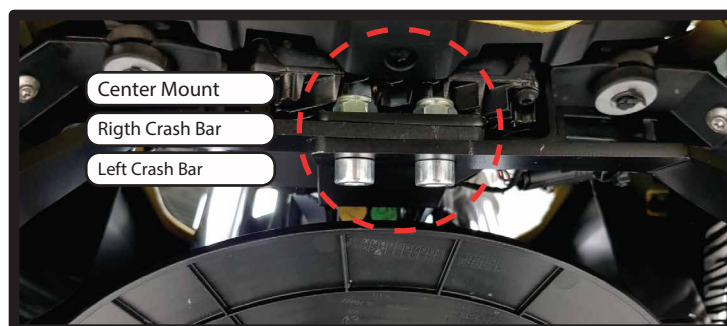

Center Mount

Rigth Crash Bar

Left Crash Bar

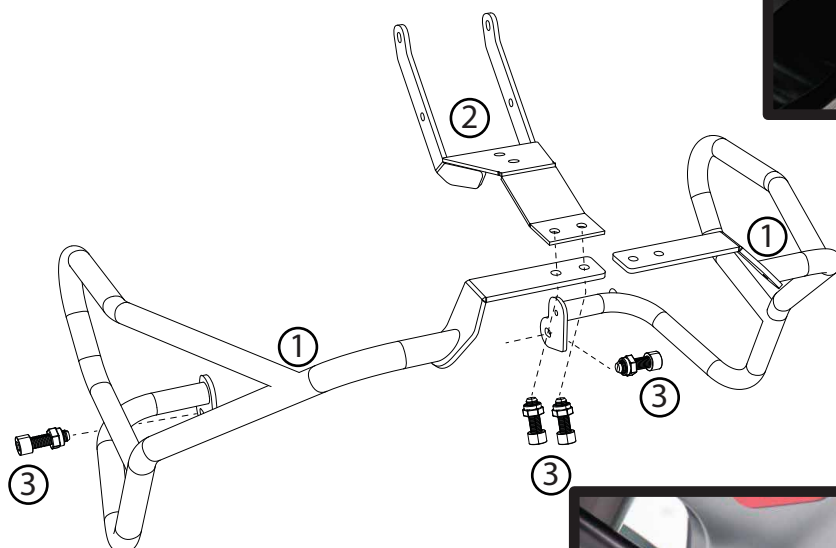

The Upper Bars are installed in the points of the plates indicated in the image, this is the same for the Left side as for the Right

Install both Crash bars in the down points over the motor protector previously installed, as show in the picture.

IMPORTANT:

The upper Crash Bar protectors
DEPEND OFF THE MOTOR PROTECTORS
previously installed of mastech brand.

This product is not compatible with
accessories of other brands.



After the installation of the parts, please check that they are aligned and that all the hardware is properly tightened